



PCC®-170SWO

The Crown® PCC-170SWO is a surface-mounted supercardioid microphone for distance learning or similar applications. The user can turn the mic on and off by pressing a membrane switch on the mic. A pair of extra leads in the mic cable allow isolated remote sensing of the microphone switch closure. In a typical distance-learning application, a video camera would track to the person who switched on the microphone.

The mic includes a bass-tilt switch, which lets the user tailor the low-end response for particular applications. A high-frequency adjust is also provided.

The membrane switch can be configured for touch on/off, momentary on, or momentary off operation. This configuration is set by a bottom-mounted DIP switch. A high-intensity LED lights when the unit is on.

The mic can be set to be always on. In this mode, the switch only activates the remote sensing and LED. This is useful when using an external gated mixer (automatic mixer).

Remote sensing is done by a patented opto-coupled MOS switching circuit. At the remote-sensing leads, the resistance goes low when the mic is on. The microphone is attenuated 70 dB when the switch is off.

How to Set the Bass Tilt Switch

On the bottom of the microphone is a BASS-TILT switch with three positions: FLAT, CUT, and BOOST. It adjusts the low-frequency response as shown in Fig. 1.

- The FLAT position provides a flat low-frequency response, (normal operation). The mic is shipped from the factory in the flat position.
- The CUT position rolls off the bass, useful in noisy or boomy surroundings.
- The BOOST position boosts the bass for a more natural sound when the mic is used on a small surface such as a lectern.

You can also adjust the high-frequency response. Insert a small screwdriver into the hole labeled "HF ADJ" on the bottom of the mic.

How to Configure the Membrane Switch

The membrane switch can be programmed to work three ways:

1. Touch on/off. Touch the switch to turn on the mic; touch it again to turn off the mic.
2. Momentary on. Touch and hold the switch to momentarily turn on the mic. Release the switch to turn the mic back off.
3. Momentary off. Touch and hold the switch to momentarily turn off the mic. Release the switch to turn the mic back on. This option

PHASE COHERENT CARDIOID® MICROPHONE



Features

- Ideal for distance learning applications
- Programmable on/off switch
- Extra leads in mic cable allow remote sensing of mic switch closure
- Half-supercardioid polar pattern reduces pickup of muddy-sounding room acoustics
- Bass-tilt switch
- Adjustable high-frequency response

Specifications

Element: Electret condenser.

Frequency response (typical): 40 Hz to 20,000 Hz at 30 degrees incidence to surface. See Fig. 1.

Polar pattern: Half-supercardioid (supercardioid in the hemisphere above the primary boundary). See Figs. 2 and 3.

Impedance: 150 ohms, balanced. (Recommended load impedance 1000 ohms or greater.)

Open-circuit sensitivity: 22 mV/Pa* (-33 dB re 1 V/Pa*).

Power sensitivity: -30.5 dB re 1 milliwatt/Pa*.
-125 dBm EIA rating.

Equivalent noise level (self noise): 22 dB SPL typical (0 dB = .0002 dyne/cm²), A-weighted.

S/N ratio: 72 dB at 94 dB SPL.

Maximum SPL: 120 dB SPL produces 3% THD.

Polarity: Positive pressure on the diaphragm produces positive voltage on pin 2 with respect to pin 3.

Operating voltage: Phantom power: 24 to 48 volts DC positive on pins 2 and 3 with respect to pin 1.

Current drain: 6.8 mA nominal.

Cable: 15-foot, black, integral to microphone, unterminated.

Off-attenuation: 70 dB at 1 kHz.

Maximum voltage and current which may be applied to remote sensing contact-closure leads: 350 V, 200 mA. Small voltages are recommended; large voltage changes may induce noise in audio output.

On-resistance: 7 to 10 ohms with the included 15-foot cable.

Cable wiring:

Shield: Audio shield.

Green: Audio in-polarity.

White: Audio opposite-polarity.

Red: Remote contact-closure sensing, +DC.

Black: Remote contact-closure sensing, -DC.

Operating temperature range: -10° to +50° C, or +14° to +122° F.

Materials: High-impact molded plastic and steel mesh grille.

Finish: Satin black.

Net weight: 6 oz. (170 g).

Dimensions: See Fig. 4.

Optional accessories: Crown PH-1A phantom

power supply (one channel, battery or AC-adaptor powered).

*1 pascal = 10 dynes/cm² = 10 microbars = 94 dB SPL.

Fig. 1 Frequency Response

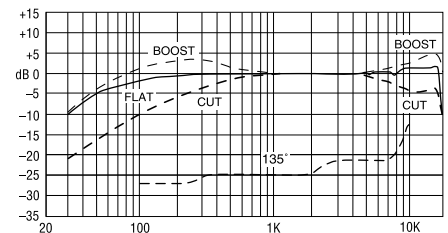

Fig. 2 Vertical Plane Polar Response

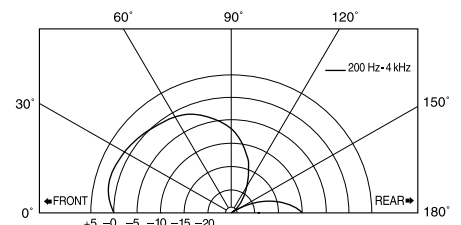
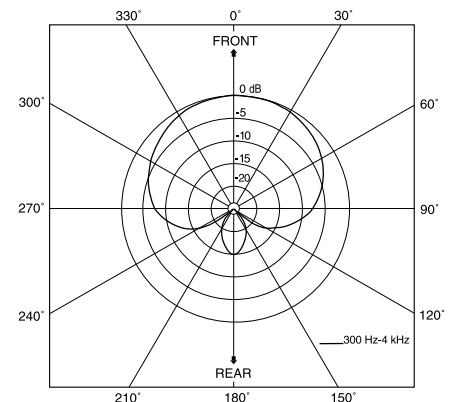

Fig. 3 Horizontal Plane Polar Response





INSTALLED

PCC-170SWO

switch will light the LED and activate remote sensing.

The contact-closure leads (red and black) provide remote sensing of mic attenuation. Switch closed (low resistance) is mic ON. Switch open (high resistance) is mic OFF.

To detect when the mic is on, apply a small voltage to the remote sensing leads (Fig. 7). Apply +DC to the red lead and -DC to the black lead. Large voltage and current may induce noise into the audio output. Maximum switch voltage and current are 350 V, 200 mA. On-resistance is 7 to 10 ohms with the included 15-foot cable.

Warranty

Crown professional microphones are guaranteed against malfunction for a period of three years from date of original purchase. Please refer to the enclosed full warranty sheet for more detail.

Service

If the microphone does not function properly, replace or repair mic cables and connectors, check the power supply. If service is required, return the microphone in its original packaging to: **Crown Factory Service, 1718 W. Mishawaka Road, Elkhart, IN 46517-9439. A Service Return Authorization (SRA) is required for product being sent to the factory for service. An SRA can be completed on line at www.crownaudio.com/support/factserv.htm.**

For further assistance or technical support call **800-342-6939**.

serves as a cough button or privacy button.

After choosing the option you prefer, set the DIP switches according to the label on the bottom of the microphone (see Fig. 5). The LED in the microphone housing will light when the mic is on.

If you want the mic to be continuously on (so you can gate it on and off externally), set the DIP switch to "DISABLE MIC GATING."

Installation

Typical placement for each microphone is at arm's length from the user. Either place one microphone in front of each person or one between every two people. The front of the microphone is indicated by an arrow on the bottom of the base plate.

If the microphone is used on a lectern, place it on an open surface, not in a cavity. Otherwise the frequency response and polar pattern will be degraded.

Solder the shield, green and white leads to an XLR type connector, shield to pin 1, green to 2, white to 3. Plug this connector into the input of a phantom-power supply such as a Crown PH-1A. Connect the output to a mixer mic input. Or if your mixer has phantom power built in, connect each mic cable directly to a mixer mic input.

Fig. 4 Dimensions

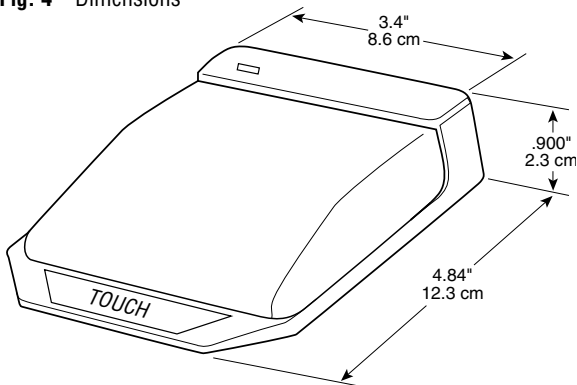
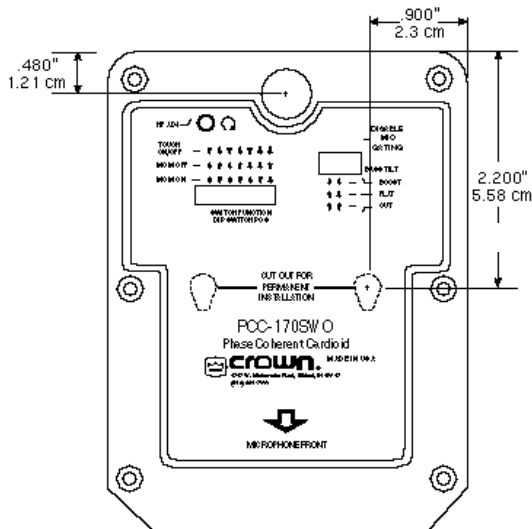

Fig. 5 Dimensions are to outside of plastic housing



The PCC includes two keyhole slots in its base to accept mounting screws. To screw the PCC to a table top, follow this procedure:

1. Punch out the keyholes marked on the label underneath the base plate (use a razor blade, small screwdriver, etc.).

Fig. 6

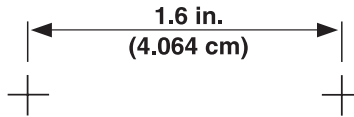

2. Using the template (Fig. 6), mark the location of two holes in the table where you want to mount the mic. These holes are 1.6-inch (4.064 cm) apart, center-to-center.

3. Screw two #8 woodscrews (.270" dia. head) into the table at the locations you marked.

4. Loosen the screws enough to receive the mic and to hold it with a friction fit.

Operation

Press near the center of the switch. The microphone will switch on or off according to how you set the DIP switches. When the mic is on, the LED in the housing is lit.

If you set the DIP switch to "DISABLE MIC GATING," the mic is always on. Pressing the

Fig. 7

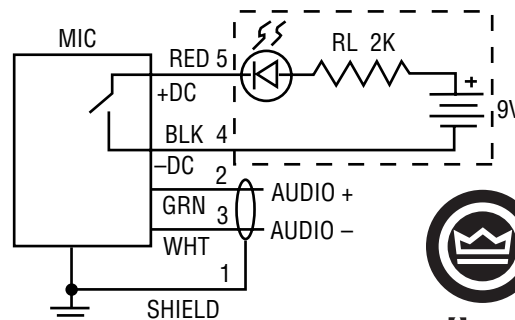

Sample circuit for remote sensing.



A Harman International Company

Crown International, Inc.
1718 W. Mishawaka Rd.
Elkhart, IN 46517-9439
TEL: 574-294-8000
FAX: 574-294-8FAX
www.crownaudio.com

©2006 Crown Audio®, Inc.

Specifications subject to change without prior notice. Latest information available at www.crownaudio.com. Crown, Crown Audio, PCC and Phase Coherent Cardioid are registered trademarks of Crown International, Inc.